



# Pyranometers

---

**FOR THE ACCURATE MEASUREMENT OF SOLAR IRRADIANCE**

Installed around the world by national networks

Specifications to ISO 9060 and IEC 60904 standards

Widely used within World Meteorological Organisation scientific programmes

The broadest range of pyranometers and accessories available

## INTRODUCTION

Solar radiation drives almost every dynamic process on the Earth's surface and above, from ocean current circulation to the weather, and life itself. Precise long-term measurements of the radiation budget at the surface are fundamental to understanding the Earth's climate system. Rising fossil fuel costs and the need to reduce Carbon footprints has produced a rapid growth in the market for 'green' energy, in which the fastest growing sector is solar power.

Scientists, researchers and commercial companies in renewable energy, climatology, weather, agriculture, water resources and environment all require accurate and reliable measurements of solar radiation. The measurement is made by pyranometers, which are radiometers designed for measuring the total (global) irradiance on a plane surface resulting from radiant fluxes in the wavelength range from 300 nanometers (nm), or less, to 3000 nm.

Kipp & Zonen has been manufacturing pyranometers for over 75 years. We produce models at all price and performance points, up to the very best available. All comply with the requirements of ISO 9060 and are fully traceable to the World Radiometric Reference (WRR) in Davos, Switzerland, where Kipp & Zonen instruments form part of the World Standard Group.

Our top level pyranometers have exceptional levelling accuracy, built-in temperature sensors and a test certificate with individually measured directional and temperature

responses. These important features ensure the highest accuracy measurements. Kipp & Zonen pyranometers are designed for a long operating life with simple maintenance and a wide range of accessories is available.

## APPLICATIONS

Kipp & Zonen pyranometers have been developed to be suitable for use in all environments, from the Antarctic to deserts. They are installed around the world for meteorology, hydrology, climate research, solar energy, environmental and materials testing, greenhouse control, building automation and many other applications.

## CHOICE OF PYRANOMETER

To achieve the required spectral and directional characteristics CMP Series pyranometers use thermopile detectors and glass or quartz domes. All models have built-in bubble levels and adjustable levelling feet. The waterproof connectors have gold-plated contacts and are fitted with 10 m of high quality signal cable as standard. The instruments do not require power and are supplied with comprehensive calibration certificates.

The most appropriate model for an application largely depends on the desired accuracy and performance.

---

**CMP 3** is smaller and lighter than the other CMP Series pyranometers. It has a robust 4 mm thick glass dome to protect the thermopile from external influences. The small size and sealed construction make this instrument the ideal choice for horticulture, monitoring solar energy installations, industrial applications, and it can be used underwater. A screw-in mounting rod is available for easy installation.

**CMP 6** has a similar detector to CMP 3, but has improved performance due to the increased thermal mass and the double glass dome construction. It is recommended for cost-effective, good quality, measurements in meteorological and hydrological networks and agriculture.

**CMP 11** uses a different detector design with temperature compensation. It is a step up in performance from CMP 6 and particularly suitable for upgrading meteorological networks. The faster response time meets the requirements for solar energy research and development applications. CMP 11 is also ideal for use in sun tracker based solar monitoring stations.





**CMP 21** is similar to CMP 11 but has individually optimised temperature compensation. A standard thermistor sensor is fitted to monitor the housing temperature. Each instrument is supplied with its own temperature and directional (cosine) response data. It is the choice for scientific use and in top level solar radiation monitoring networks such as the Baseline Surface Radiation Network (BSRN) of the World Meteorological Organisation.

**CMP 22** has all the features of CMP 21 but uses very high quality quartz domes for a wider spectral range, improved directional response, and reduced thermal offsets. Because of the high optical quality of these domes the directional error is reduced below 0.5% up to 80 ° solar zenith angle. Kipp & Zonen is confident that CMP 22 is the best pyranometer currently available.

## BUILDING A SYSTEM

The system capabilities of Kipp & Zonen pyranometers can be extended with our wide range of compatible products and accessories. Please refer to our website [www.kippzonen.com](http://www.kippzonen.com) for more information on the following products.

### Albedometer

To calculate Albedo the incoming global radiation is measured by a pyranometer facing upward and the radiation reflected by the ground is measured by a pyranometer facing downward. CMA 6 and CMA 11 are integrated Albedometer versions of CMP 6 and CMP 11. Details can be found in our dedicated Albedometer brochure.

### Ventilation Unit

CVF 3 ventilation unit is designed for use with all CMP Series pyranometers (except the CMP 3). Ventilation helps to keep the dome clean and reduces infrared thermal offsets by stabilization of the dome temperature. The two levels of heating can be used to remove raindrops, dew, frost and snow.

### Shadow Ring

The combination of a pyranometer and a CM 121 shadow ring offers a simple solution for measuring diffuse radiation from the sky. The ring only requires simple adjustment every few days to ensure that the shadow covers the pyranometer dome completely as the sun moves across the sky.

### Sun Tracker

SOLYS 2 and 2AP sun trackers are all-weather reliable instruments used to accurately point a pyrliometer at the sun for direct radiation measurements. When fitted with an optional shading assembly and a pyranometer they measure diffuse radiation with no need for periodic manual adjustments. Adding a second pyranometer for the global radiation makes a high quality solar monitoring station.

### Amplification

Pyranometers have low output signals in the mV range. AMPBOX converts this to the industrial standard 4 - 20 mA current loop signal and provides a defined output range in W/m<sup>2</sup>. Amplification is advised for noisy environments, use with data acquisition equipment with high-level inputs, and for very long cables (> 100 m).

### Data loggers

Kipp & Zonen has a range of high performance data logging and display products for use with CMP series pyranometers and our other solar radiometers.

### Mounting plates

Kipp & Zonen offers two mounting fixtures suitable for all CMP series pyranometers. CMF 1 is a small round plate with integral rod for mounting upward and/or downward facing pyranometers. CMF 2 is a larger version that can also be used for mounting pyranometers fitted with the CVF 3 ventilation unit.

### Glare Screen Kit

A downward facing pyranometer should not see any radiation coming from the hemisphere above or from the first 5 ° below the horizon. To prevent this, a glare screen kit is available for use with all CMP series pyranometers (except the CMP 3).



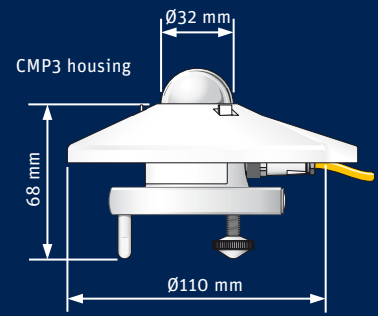
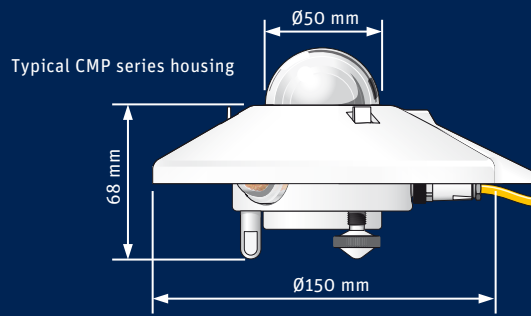

| Specifications   | CMP 3   | CMP 6  | CMP 11   | CMP 21   | CMP 22  |
|--|---|--|--|--|---|
| ISO CLASSIFICATION   | Second Class  | First Class  | Secondary Standard   | Secondary Standard   | Secondary Standard  |
| Response time (95 %)   | < 18 s  | < 18 s   | < 5 s  | < 5 s  | < 5 s   |
| Zero offsets<br>(a) thermal radiation (200 W/m <sup>2</sup> )<br>(b) temperature change (5 K/hr) | < 15 W/m <sup>2</sup><br>< 5 W/m <sup>2</sup>   | < 15 W/m <sup>2</sup><br>< 4 W/m <sup>2</sup>  | < 7 W/m <sup>2</sup><br>< 2 W/m <sup>2</sup>   | < 7 W/m <sup>2</sup><br>< 2 W/m <sup>2</sup>   | < 3 W/m <sup>2</sup><br>< 1 W/m <sup>2</sup>  |
| Non-stability (change/year)  | < 1 %   | < 1 %  | < 0.5 %  | < 0.5 %  | < 0.5 %   |
| Non-linearity (0 to 1000 W/m <sup>2</sup> )  | < 1 %   | < 1 %  | < 0.2 %  | < 0.2 %  | < 0.2 %   |
| Directional error<br>(up to 80 ° with 1000 W/m <sup>2</sup> beam)                                | < 20 W/m <sup>2</sup>   | < 20 W/m <sup>2</sup>  | < 10 W/m <sup>2</sup>  | < 10 W/m <sup>2</sup>  | < 5 W/m <sup>2</sup>  |
| Temperature dependence<br>of sensitivity   | < 5 %<br>(-10 °C to +40 °C)   | < 4 %<br>(-10 °C to +40 °C)  | < 1 %<br>(-10 °C to +40 °C)  | < 1 %<br>(-20 °C to +50 °C)  | < 0.5 %<br>(-20 °C to +50 °C)   |
| Tilt error (at 1000 W/m <sup>2</sup> )   | < 3 %   | < 1 %  | < 0.2 %  | < 0.2 %  | < 0.2 %   |
| <b>Other specifications</b>  |   |  |  |  |   |
| Sensitivity  | 5 to 20 μV/W/m <sup>2</sup>   | 5 to 20 μV/W/m <sup>2</sup>  | 7 to 14 μV/W/m <sup>2</sup>  | 7 to 14 μV/W/m <sup>2</sup>  | 7 to 14 μV/W/m <sup>2</sup>   |
| Impedance  | 20 to 200 Ω   | 20 to 200 Ω  | 10 to 100 Ω  | 10 to 100 Ω  | 10 to 100 Ω   |
| Level accuracy   | 1 °   | 0.1 °  | 0.1 °  | 0.1 °  | 0.1 °   |
| Operating temperature  | -40 °C to +80 °C  | -40 °C to +80 °C   | -40 °C to +80 °C   | -40 °C to +80 °C   | -40 °C to +80 °C  |
| Spectral range (50 % points)   | 300 to 2800 nm  | 285 to 2800 nm   | 285 to 2800 nm   | 285 to 2800 nm   | 200 to 3600 nm  |
| Typical signal output for<br>atmospheric applications  | 0 to 20 mV  | 0 to 20 mV   | 0 to 15 mV   | 0 to 15 mV   | 0 to 15 mV  |
| Maximum irradiance   | 2000 W/m <sup>2</sup>   | 2000 W/m <sup>2</sup>  | 4000 W/m <sup>2</sup>  | 4000 W/m <sup>2</sup>  | 4000 W/m <sup>2</sup>   |
| Expected daily uncertainty   | < 10 %  | < 5 %  | < 2 %  | < 2 %  | < 1 %   |
| Recommended applications   | Economical solution<br>for routine<br>measurements in<br>weather stations,<br>field testing | Good quality<br>measurements for<br>hydrology networks,<br>greenhouse climate<br>control | Meteorological<br>networks, PV panel<br>and thermal collector<br>testing,<br>materials testing | Meteorological<br>networks, reference<br>measurements in<br>extreme climates,<br>polar or arid | Scientific research<br>requiring the highest<br>level of measurement<br>accuracy and<br>reliability |
| CMP instruments have a standard cable length of 10 m. Optional cable lengths 25 m and 50 m       |   |  |  |  |   |
| Standard 10k Thermistor or optional Pt-100 temperature sensor with CMP 21 and CMP 22             |   |  |  |  |   |
| Individual directional response and temperature dependence test data with CMP 21 and CMP 22      |   |  |  |  |   |

Note: The performance specifications quoted are worst-case and/or maximum values



Go to [www.kippzonen.com](http://www.kippzonen.com) for your local distributor

## HEAD OFFICE

**Kipp & Zonen B.V.**  
 Delftechpark 36, 2628 XH Delft  
 P.O. Box 507, 2600 AM Delft  
 The Netherlands  
 T: +31 (0) 15 2755 210  
 F: +31 (0) 15 2620 351  
 info@kippzonen.com

Kipp & Zonen B.V. reserve the right to alter specifications of the equipment described in this documentation without prior notice

4414470 - V1007